

46in length

94in length

Included components:

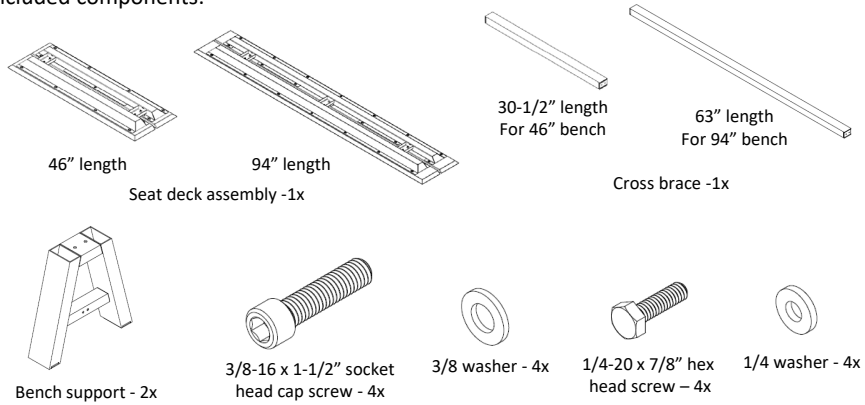

Tools required for assembly

- Safety glasses
- 5/16 hex key/bit
- 7/16" socket wrench
- Protective padding material

PROCEDURE FOR ASSEMBLY:

**Note:** DO NOT DRAG bench across concrete or other rough surfaces. This could damage the powdercoat finish. After inspecting parts, packaging skid and materials may be used for assembling units. Loosely install all hardware until unit is fully assembled. Tighten hardware.

1. Place bench seat upside down on protective padding.
2. Set supports in approximate position.
3. Install washers and 3/8 socket head cap screws, 2 per support, as shown in Fig. 1.
4. Install cross brace to supports using 1/4-20 hex head screws and washers, 2 per side, see Fig. 2.
5. Turn bench upright and set in position.

**ASSEMBLE WITH CARE!** Pangard II® Polyester Powdercoat is a strong, long-lasting finish. To protect this finish during assembly, place unwrapped powdercoated parts on packaging foam or other non-marring surface. Do not place or slide powdercoated parts on concrete or other hard or textured surface – this will damage the finish causing rust to occur. Use touch-up paint on any gouges in the finish caused by assembly tools.

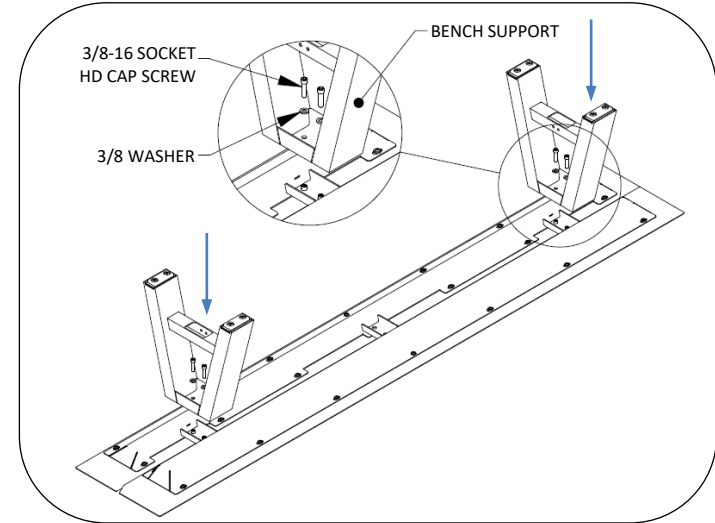

Fig. 1 – attach supports to bench seat

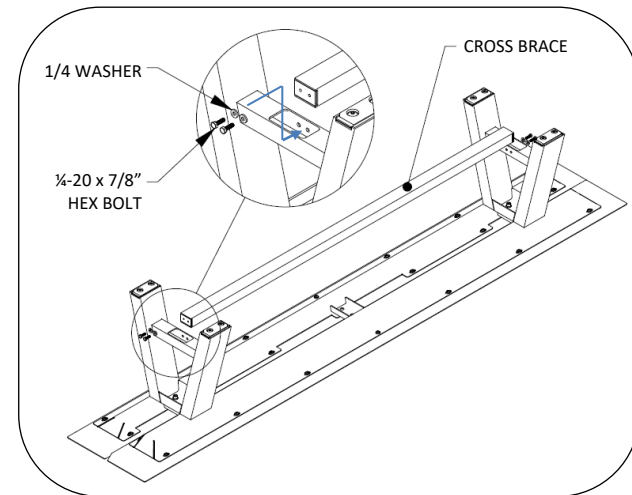

Fig. 2 – attach cross brace to supports