

Units include (4) M16 x 140mm bolts for anchoring.
Units must be anchored

Tools Required:

- Crane or proper equipment to move 2027 lbs
- Non-Marring Straps
- Wrench, 24mm
- Chemical Anchoring Adhesive
- Hammer drill with Ø1-1/2" dia masonry drill bit

NOTE: Items will deliver on pallets in closed freight containers. Appropriate equipment will be required to offload from a closed container. Flatbed delivery is possible upon request and for an additional charge. Strapping is indicated as a method of placing the item on the project site.

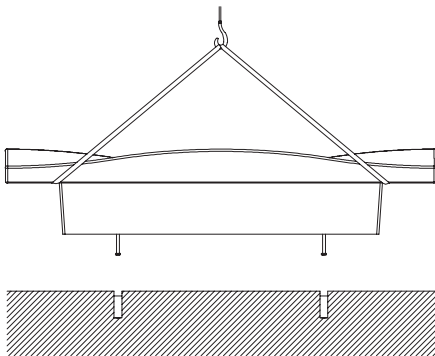
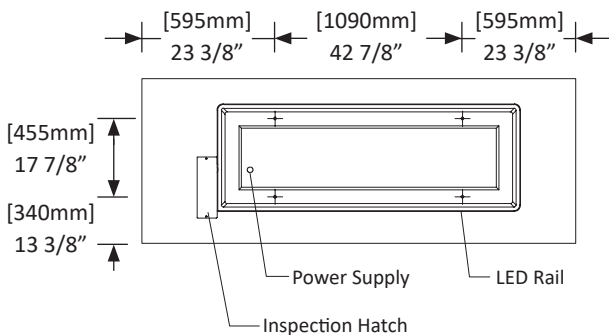

Fig. 1 Crane Install - Strap Locations (anchored)



LED	
Operating Voltage	24V
Power	15W/m
Color temperature	3000K / 6000K
Degree of protection	IP67

Installation (must be anchored)

1. Determine placement of Bench.
2. Set in place with proper equipment such as a crane. See Fig. 1
2. Mark hole locations.
3. Drill holes according to Fig. 2.
4. Lift unit and install M16 x 140mm bolts (Qty 4). Thread in until tight.
5. Fill holes with chemical anchoring adhesive
6. Lower unit over holes.
7. Caulk around entire bench foot bottom of the bench.

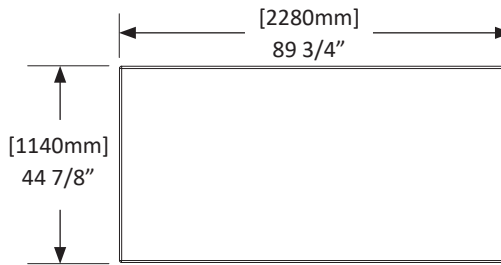
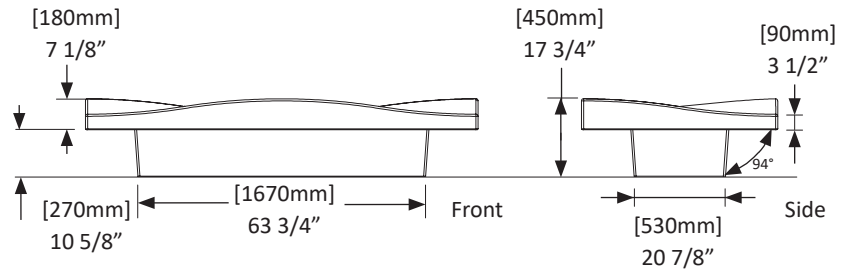

Configurations

