

# kaleidoscope<sup>®</sup>

assembly guide



landscapeforms<sup>®</sup>

## table of contents

---

<b>Section 1</b>	
Ground Preparation and Footings	2
<b>Section 2</b>	
Setting the Posts	3
Canopies	4
Lighting	8
Seating	9

## section 1: recommended ground preparation and footings

---

Landscape Forms is not responsible for site preparation and footings. Contact Landscape Forms for structural information, including base plate dimensions, anchor hole size and spacing and locating notch. **Templates are shipped with every order. However, if you are using cast-in-place anchors, please call in advance of order shipment for templates.**

**Note: Landscape Forms does not provide anchor bolts, leveling nuts, or washers.**

---

### SUGGESTED GROUND PREPARATION AND FOOTING.

Landscape Forms is not responsible for site preparation and footings. Landscape Forms does not provide anchors, leveling nuts or washers.

All of Landscape Forms suggested footing details are subject to local building restrictions. It is the responsibility of the installer to acquire all permits, inspections, building official compliance, and to determine local frost, wind, exposure, snow, and soil requirements.

There shall be no implied liability on the part of Landscape Forms for the suggested footings and other conditions suggested for the below grade anchorage of the Kaleidoscope system.

Contact Landscape Forms for the following Kaleidoscope OS foundation plans:

Caisson:

- 90 MPH exposure B; 40 PSF snow load
- 146 MPH exposure C

Slab:

- 90 MPH exposure B; 40 PSF snow load
- 146 MPH exposure C

Spread:

- 90 MPH exposure B; 40 PSF snow load
- 146 MPH exposure C

Exposure B: Defined as having terrain with buildings, forest or surface irregularities covering at least 20% of the ground level area extended one mile or more from the site.

Contact Landscape Forms for footing recommendations for Kaleidoscope I.



# kaleidoscope® assembly guide

## setting the posts



### Landscape Forms provides installation drawings for every order.

The base of every post is stamped with an identification number which corresponds with post numbers on the installation drawing.

There is a locating notch on each post that is shown on the installation drawing. This will guide you in setting posts in the proper direction.

It is critical to the alignment of all components that each post be installed in its proper location and direction.

### Tools Needed

Boom crane, level, tape measure, nylon string, large adjustable wrench.  
Anchor bolts, leveling nuts and washers to be provided by others.

### Post Installation Instructions

1. Verify the bolt layout and center to center distance of the anchoring bolts in and between footings before starting to install the posts. See Suggested Ground Preparation and Footing details to verify the required dimensions from top of footing to finished grade and minimum and maximum column base plate clearances.
2. Install the bottom leveling nuts and washers on to the anchor bolts.
3. Attach lifting strap to post hub as shown (if using boom crane).
4. Using boom crane, lift post onto anchoring bolts. **Note:** Orient locating notch in base plate as shown on installation drawing included with this package.
5. Install nuts and washers on top of base plate, plumb and level posts. Do not fully tighten nuts at this time; posts may need to be adjusted.
6. Install the remaining posts in the same manner.
7. Check post to post alignment as well as center to center dimensions.
8. Check to make sure posts are the same height across the top of the posts.

## canopies

### 2 Post Canopy Installation

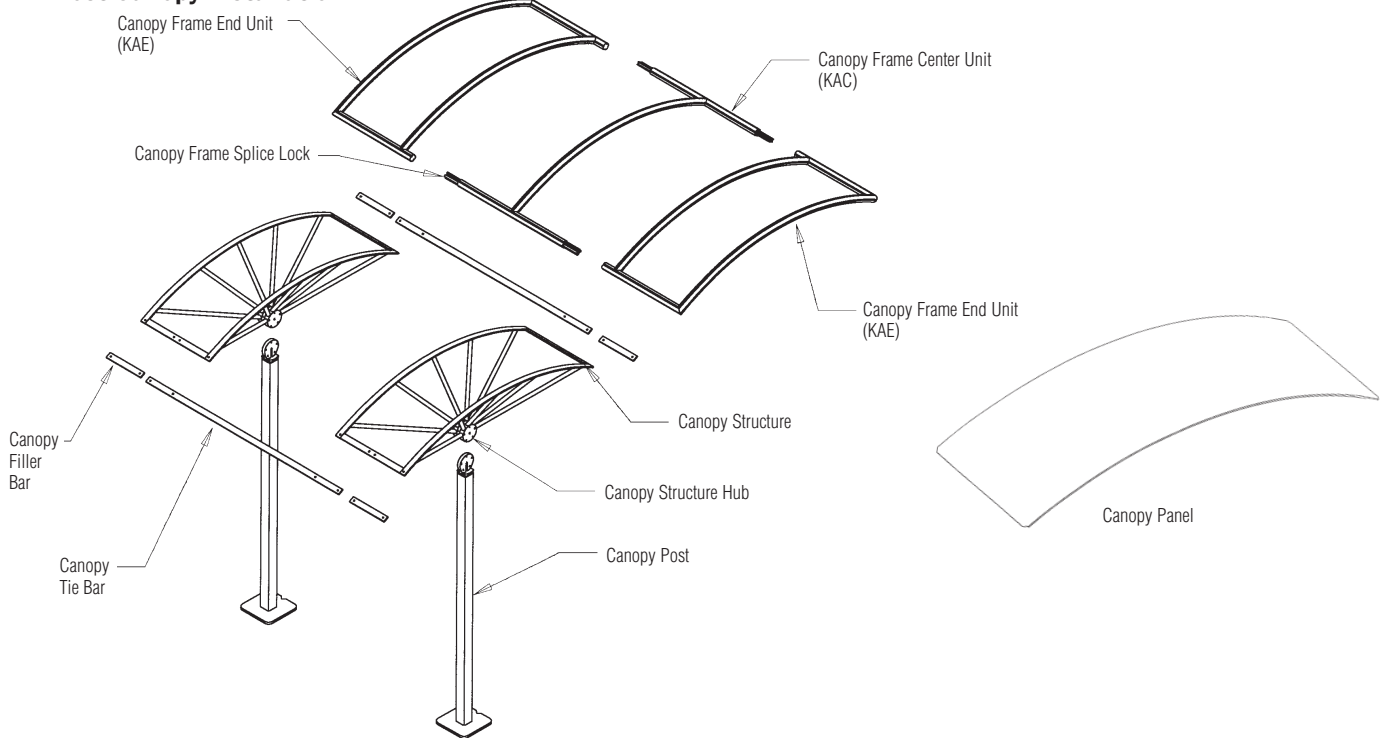

### 3 or More Post Canopy Installation

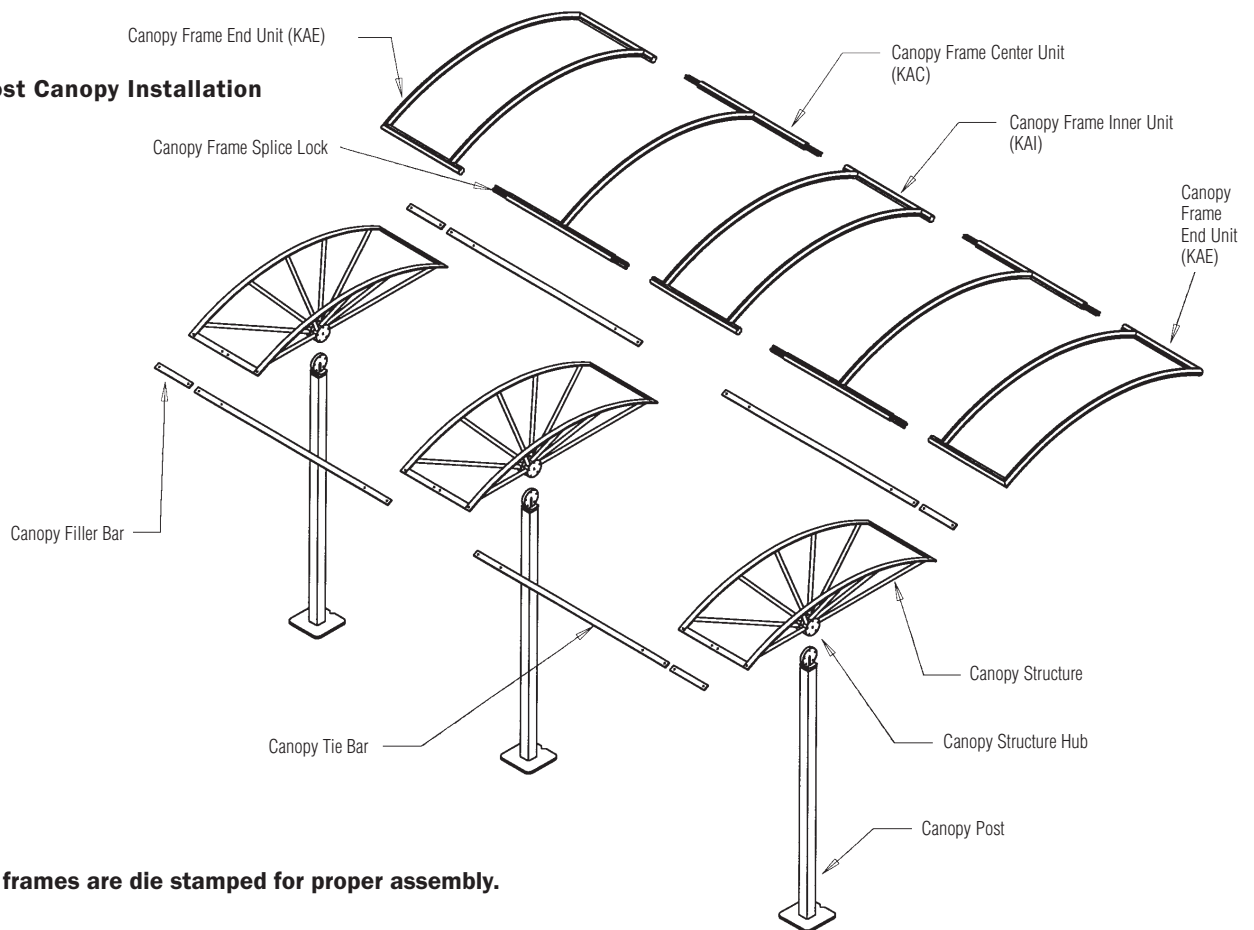

**Note: Canopy frames are die stamped for proper assembly.**

# kaleidoscope® assembly guide

## canopies

continued

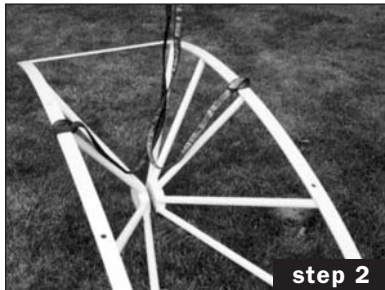

### Canopy Structure Hardware Package

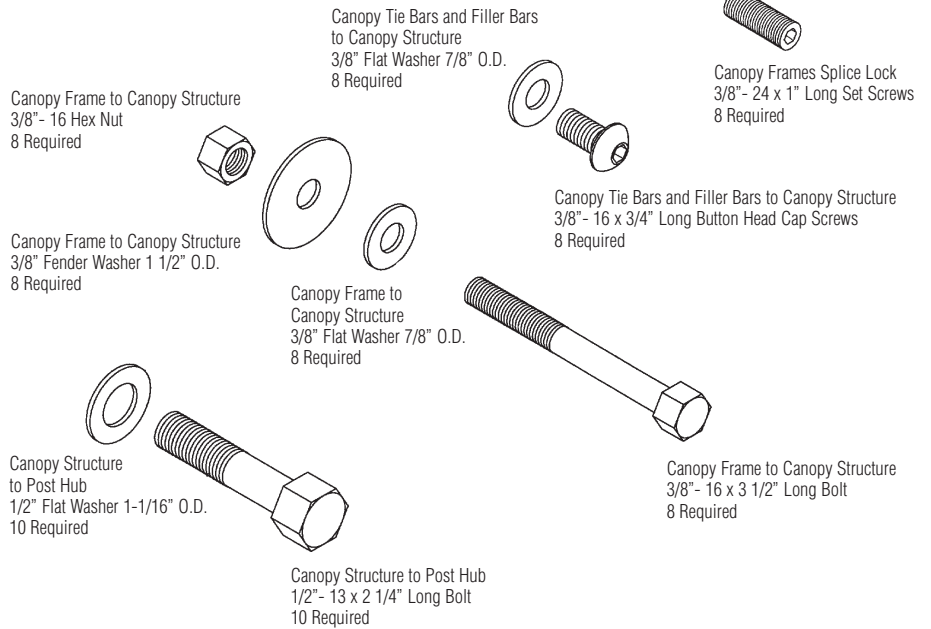

### Tools Needed (SAE)

Boom crane, scaffold, level, tape measure, 9/16" and 3/4" socket and ratchet, allen wrench set, chalk line, line level.

### Canopy Installation Instructions

**Note:** Canopy frames are die stamped for proper assembly.

1. Remove shipping spacer from between hubs of canopy structure.
2. Attach lifting strap to canopy structure for lifting as shown.
3. Using boom crane, lift the canopy structure on to post hub as shown.
4. Bolt the canopy structure to the post using the 1/2" -13 x 2-1/4" long bolts and flat washers supplied in the hardware package (10 required per post). Do not fully tighten at this time.
5. Install the remaining canopy structures in the same manner.
6. On installations of 3 or more posts, use a chalk line to align the canopy structure.
7. Level canopy structure and check alignment with each other as shown and tighten canopy structure to post bolts to 75ft•lbs.

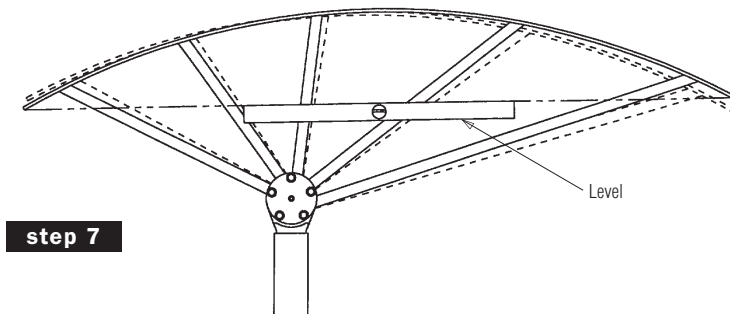

# kaleidoscope® assembly guide

## canopies

continued

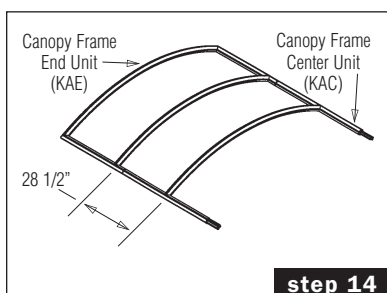
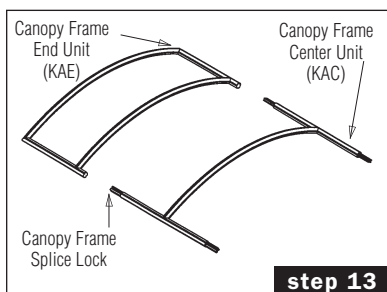

8. Bolt the canopy tie bars to the canopy structure using the 3/8" -16 x 3/4" long button head bolts and washer supplied in the hardware package (4 required per bar). Start by installing the 2 bolts in one end and tighten to 20 ft•lbs., then install the bolts on the other end of the tie bar. **NOTE:** It is very likely that you will have to adjust the canopy structure and or the post at this time, the tie bars should be flush with the front edge of the structure and tighten each to 20 ft•lbs.
9. Check the canopy for square by measuring corner to corner as shown. Check the centerline to centerline dimension, which should be 85-1/2".

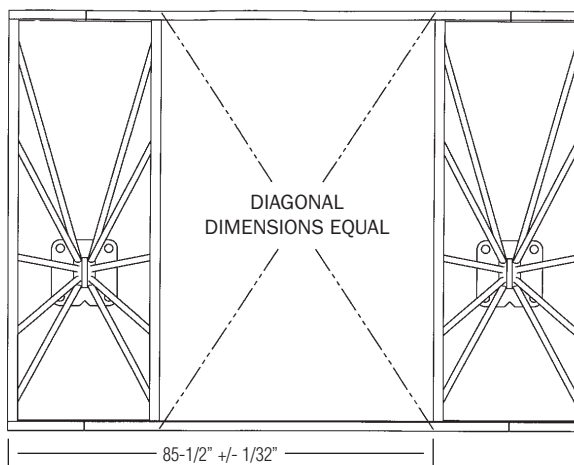

10. Bolt on the filler bars to the canopy structure using the 3/8" -16 x 3/4" long button head bolts and washers supplied in the hardware package (2 required per bar). Filler bars should be flush with the front edge of canopy structure; tighten bolts to 20 ft•lbs.
11. Lift canopy frame end unit (KAE) into place and bolt onto the canopy structure using the 3/8" -16 x 3-1/2" long bolts, hex nuts, 7/8" O. D. flat washers, and 1-1/2" O. D. flat washers; do not fully tighten at this time. **NOTE:** the 1-1/2" O. D. flat washers are installed on the underside of the canopy.
12. Loosen the 8 set screws that hold the splice locks in place 3 turns to allow ease of installation.
13. Lift the canopy frame center unit (KAC) into place and slide the splice locks into the end frame extrusion. Bolt onto the canopy structure using the 3/8" -16 x 3-1/2" long bolts. Lock nuts, 7/8" O D. flat washers, and 1-1/2" O. D. flat washers, do not fully tighten at this time. **NOTE:** The 1-1/2" O. D. flat washers are installed on the underside of the canopy. Do not fully tighten at this time.
14. Install the 3/8" -24 x 1" long set screws into the other end of the splice locks. Make sure that the measurement between the bowed tubes centerline to centerline is 28-1/2". Tighten all set screws to 18 ft•lbs.
15. On a two-post installation install the other canopy frame end unit (KAE) in the same manner.
16. On a three or more post unit install the canopy frame inner unit (KAI) in the same manner as shown. The last canopy frame member will be an end frame unit.
17. Visually check alignment of all canopy frames on the canopy structure and then torque all the 3/8" -16 x 3-1/2" long bolts to 30 ft•lbs.

# kaleidoscope® assembly guide

## canopies

continued



18. To install the canopy panels **make sure that the flanged edge is down**. The panels are flexible. Beginning in the center of the canopy frame, slide the panel into the slot on the frame. Flex the other end of the panel into place and center in the frame. **NOTE:** The panel will be loose in the frame at this time.
19. Install vinyl panel strips on the topside of the panels. Make sure it is fully seated in the frame extrusion as shown in the illustration. **NOTE:** For easier installation, the vinyl strip may be lubricated with soapy water.
20. Install the remaining canopy panels in the same manner.
21. The post anchor nuts can be tightened to 350 ft•lbs.



### Canopy Panel Strip Installation Detail

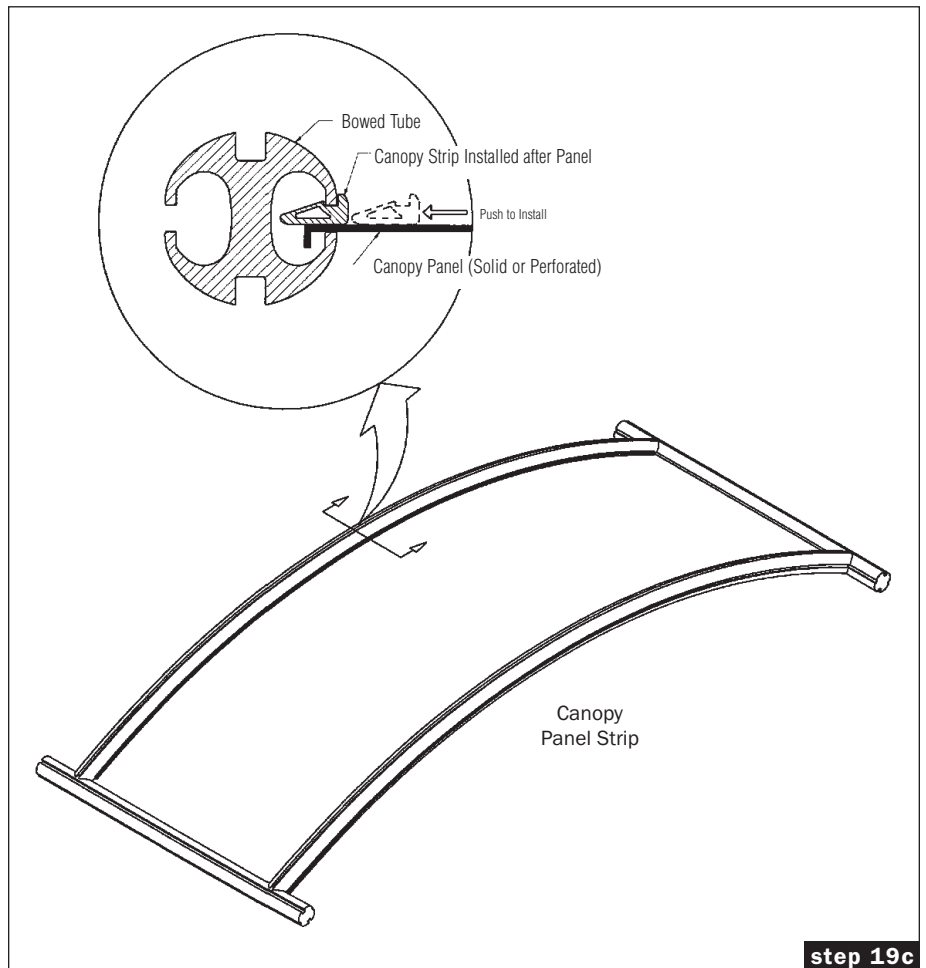

# kaleidoscope® assembly guide

## lighting



### Lighting Installation Instructions

Lighting purchased through Landscape Forms Inc. is low voltage (12 VAC). All components are UL listed. The lighting package consists of 1 light and transformer. Wiring and bulb are not provided.

Landscape Forms Inc. recommends a licensed electrical contractor install the lighting.

Landscape Forms Inc. is not responsible for verifying that the lighting and components meet local codes.

1. Remove the hex socket pipe plug in canopy structure hub and discard. The post hub has a wire slot for fishing wires into the posts. The 4" square posts are hollow to allow wiring to pass through and out the hole in the base plate.

**NOTE:** No additional holes may be drilled into the post for any reason.

2. Thread the lights into the 1/2" pipe thread hole in the hub and adjust light direction as desired. All electrical connections are the responsibility of the customer.

### Smart Shelter Lighting:

See Smart Shelter lighting system *Operation and Maintenance Manual* for more information.

## seating

### Seat Assembly Installation Instructions

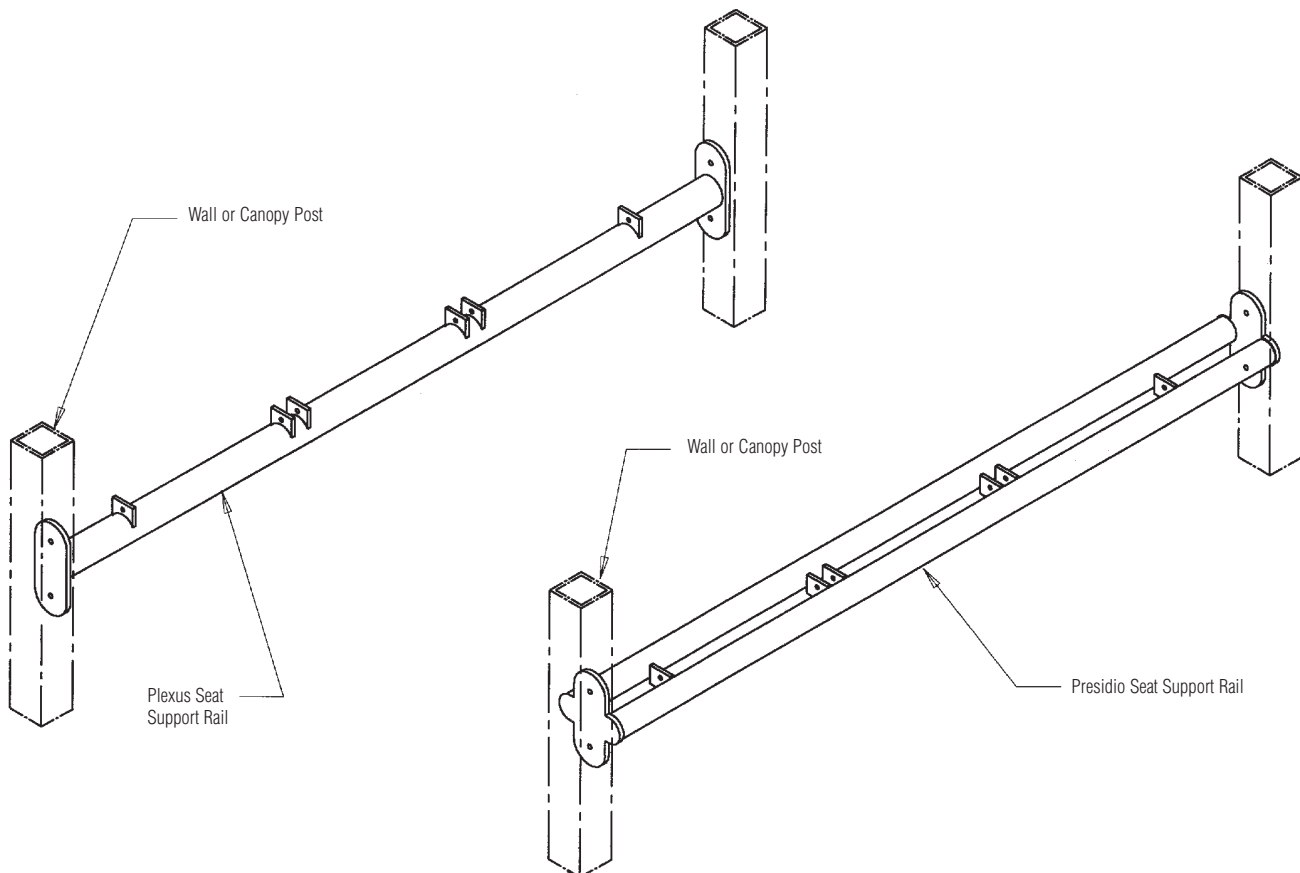

## seating

continued

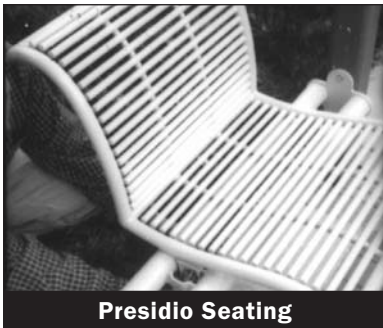

### Seat Attachment Hardware

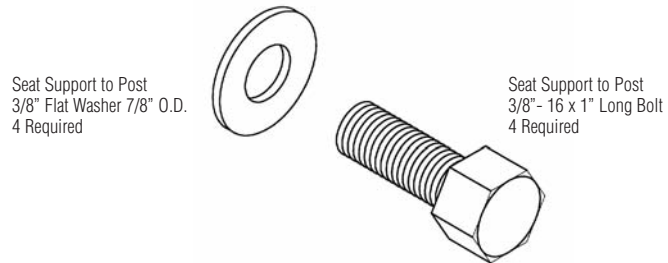

### Tools Needed (SAE)

Ratchet, 9/16" socket.

### Seat Assembly Instructions

1. Bolt seating support rail to posts using 3/8" -16 x 1" long bolts and flat washers; tighten to 30 ft • lbs.
2. Install the seats onto the seating rail.

### Presidio Seat Assembly:

1. Because these units are quite heavy, we recommend using two people to install seat(s). Set seats in front of horizontal tube sections.
2. Hold first seat above tube and slip adapters on horizontal tube.
3. Insert bolts and install lock nuts for this seat. Tighten VERY SECURELY. These are grade 5 bolts that will not break. (We recommend tightening the bolts on each seat before installing the following seat, this makes it easier to fully tighten the bolt.)
4. Check to see if seat rocks at all. If seat rocks, keep tightening until it is totally stable.
5. Continue in same manner with other seats, tightening bolts securely as you add each seat.

### Plexus Seat Assembly:

1. Set seats in front of horizontal tube sections.
2. Holding seat above tube, slip adapters on seat into channel of adapters on horizontal tube. If two people help, this is much easier.
3. If arms are used, DO NOT INSTALL BOLTS NOW. See arm assembly.
4. If arms are not used, insert bolts from the outside, toward the center of the seat and install lock nuts. Tighten VERY SECURELY. Seats will not rock if tightened correctly.

### Arm Assembly for Seats with Back:

1. Arms are manufactured to fit to the right and left of seating. These are not interchangeable and will fit on unit only one way. As you sit in the seat, arms install at the right of each seat. Place arm with adapter adjusted to fit left of the end of seating run.
2. Holding arm above tube, slip arm adapter into channel on horizontal tube against seat adapter.
3. Insert bolt from the outside, toward the center of the seat and install lock nut. Tighten very securely.

# kaleidoscope® assembly guide

Kaleidoscope designed by Robert Chipman, ASLA;  
Brian Kane, IDSA; and Arno Yurk, AIA, IDSA.  
Kaleidoscope design is protected by Patent Numbers: D432,665; D420,812;  
D421,132; D429,000; D412,993; D413,314; D420,233; D420,812.

Specifications are subject to change without notice.

Kaleidoscope is manufactured in U.S.A.

©2011 Landscape Forms, Inc.

Printed in U.S.A.

## **OUR PURPOSE IS TO ENRICH OUTDOOR SPACES**

We believe in the power of design and its ability to influence and elevate the quality of public space. High quality products and outstanding customer experience make us one of the world's premier designers and manufacturers of outdoor commercial furnishings.

**landscapeforms®**

P 800.521.2546 F 269.381.3455  
431 Lawndale Avenue, Kalamazoo, MI 49048  
email [specify@landscapeforms.com](mailto:specify@landscapeforms.com)  
[www.landscapeforms.com](http://www.landscapeforms.com)

# kaleidoscope® smart shelter

installation/maintenance manual



landscapeforms®

# kaleidoscope® smart shelter installation/maintenance manual

## table of contents

---

Installation	1
Maintenance/Product Care	4
Operation	5
Troubleshooting	6
Mechanical Installation Locations	7

### Introduction

Thank you for purchasing the Kaleidoscope Smart Shelter solar powered lighting kit, “the world’s most advanced solar powered LED lighting system for transit shelters.” The Smart Shelter is intended to increase the safety, security and visibility of transit customers waiting at night. Combining advanced electronics and software with an innovative, patented combination of solar-power and LED technology, The Smart Shelter is the most advanced transit lighting system available.

The Smart Shelter provides a warm white LED based light for the interior illumination of a non-ad panel bus shelter. This product has been designed to operate reliably under all environmental conditions at most locations across North America.

### How It Works

The Kaleidoscope Smart Shelter solar lighting system is intended to provide illumination for the interior of the transit shelter. Electrical power is delivered to the luminaires (light fixtures) from the battery bank by the Energy Management System (EMS). The EMS is also responsible for charging the batteries using electrical power from the photovoltaic array. The Photovoltaic array is monitored by the EMS for detection of nightfall and daybreak. Its main functional subsystems are given below.

1. Photovoltaic (PV) array (solar panels)
2. Battery bank
3. LED luminaire
4. Energy Management System (EMS)

**PV Array (Solar Panel):** The PV array is composed of two 20 W flexible solar modules (40W total). The panel is connected to the charging circuitry to provide enough solar power to operate the system, even in the winter months.

**Batteries:** The Battery bank is composed of three 12 Volt batteries. The batteries are sealed lead acid rechargeable with excellent temperature performance and very long life.

**Luminaires:** The LED luminaires contain high power warm white LEDs. The luminaires are driven well below their maximum power rating to increase efficiency and extend the already long life.

**EMS:** The Energy Management System is the “brain” of the lighting system. It controls charging of the batteries, and regulates the power to the LED luminaires. It has sophisticated power management algorithms that have been refined over years of field-testing. It provides two main power management strategies:

1. Automatic Light Control (ALC)
2. Low Voltage Disconnect (LVD)

ALC monitors the state of charge of the batteries to maintain operation during the winter months. Should the batteries become overly discharged, the system enters low voltage disconnect to prevent damage by over-discharging the batteries. In this state, the LED luminaires will not light during the night. The system will remain in this state until the batteries are charged to 12.8v.

### Understanding Your Product

The Smart Shelter does not need to be wired to an external power supply as it operates using a solar charged battery that is maintenance free. The Smart Shelter utilizes two 20W solar panels (40W total) and a charge control system to efficiently and effectively charge the batteries each day.

The unit is completely automatic, illuminating from dusk to dawn. Using the solar panels mounted on the roof of the shelter tells the microcontroller if it’s daytime or nighttime. Light is provided throughout the night without interruption, increasing security and safety.

## installation

1. Remove the lid to the power unit by removing the 6 fasteners.
2. Bolt the front of the solar panels to the bottom of the power unit – 3 bolts/nuts.
3. Raise power unit and attached solar panel to the roof.
4. Space the power unit 2.5" back from the front edge of the canopy.
5. Mark the location and drill and tap (4) 5/16-18 holes to secure the power module to the canopy.

### System Components Overview

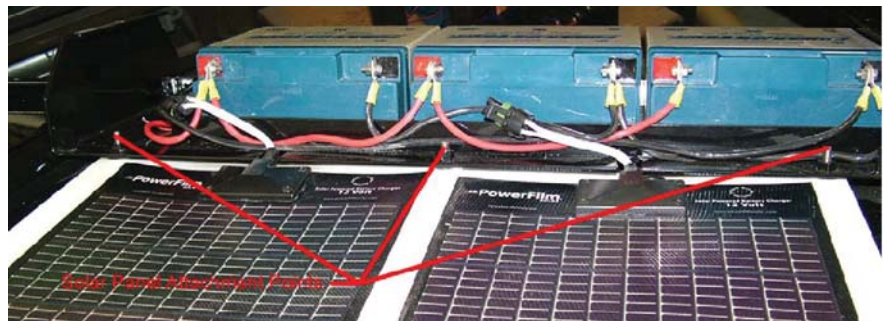
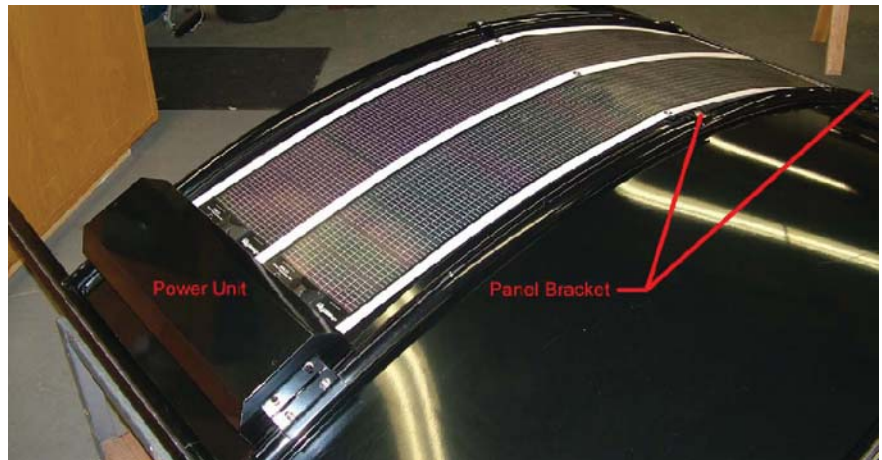

## installation continued

6. Attach panel bracket #1 and #2 to the solar panels using (6) ¼-20 flat head cap screws.
7. Place the panel brackets on the canopy and adjust the tension of the solar panels by pulling panel bracket #1 away unit. Then drill and tap (4) 5/16-18 holes to secure the panel brackets to the canopy.

**Note: At this point the two mounting brackets with the solar panels, and the power unit should all be mounted to the shelter roof**

8. Mount luminaire to interior of shelter by centering on roof arc (see installation positions - page 7). Drill and tap ¼-20 hole in shelter using luminaire base to locate holes. Fix luminaires to shelter using supplied ¼-20. Luminaires should be positioned to direct light straight toward ground. Pull wire harness from luminaire module back to power module. Route wire using interior cavity of shelter roof arcs.
9. Wiring harnesses from the solar panel and luminaires should be pulled through power module access slot (same slot as solar panel wires).

### System Components Overview

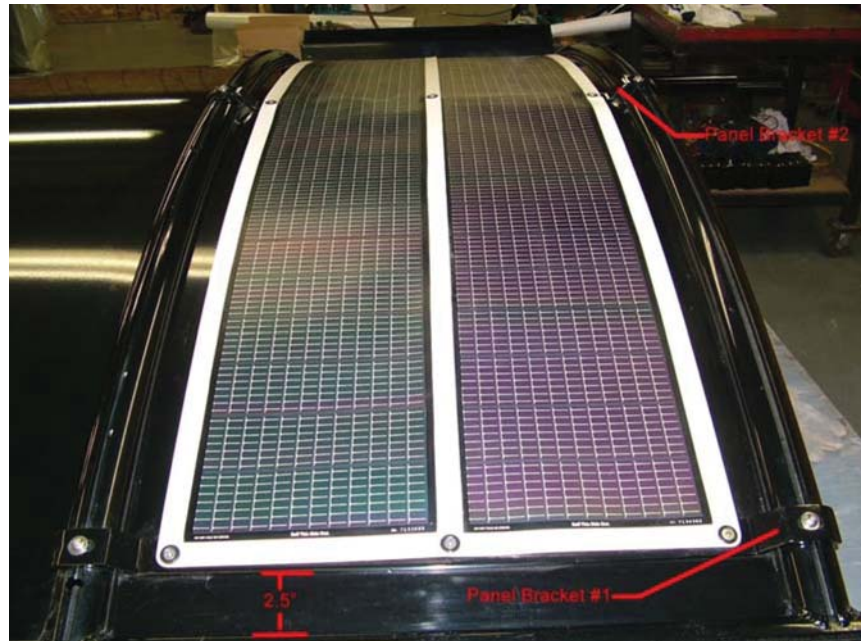

## installation continued

10. Plug the solar panels in to the Weather Pak connectors. Next plug the luminaire in to the LED Driver (match the red to red and black to black).

**Note: On units with two luminaires the wiring is as follows:**

- A. Connect the red wire from luminaire 1 to the red wire of the LED driver.
- B. Connect the red wire from luminaire 2 to the black wire of luminaire 1.
- C. Connect the black wire from luminaire 2 to the black wire of the LED driver.

**All electrical connections are complete at this point.**

11. Switch the battery disconnect to the ON position.
12. Before re-installing power module lid (removed in Step 1), complete system test as follows:
  - Press the “test” button on the MorningStar control. At this point the luminaire(s) should be lit.
13. After completion of test procedure, secure power module lid using six #10-32 fasteners.

**The installation process is now complete.**

### System Components Overview



**USE EXTREME CAUTION WHEN INSTALLING BATTERY HARNESS. ALWAYS WEAR INSULATING GLOVES WHEN CONNECTING BATTERIES.**

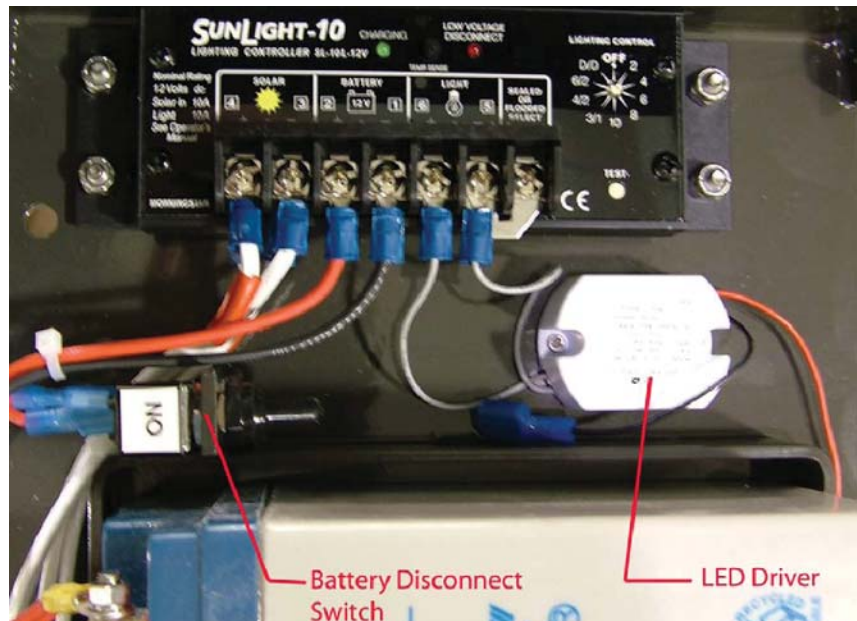

## maintenance/product care

---

Although the system is designed to be maintenance free, large performance gains can be made with clean solar panels. Clean on an annual basis or as required. Use water and a soft sponge or cloth for cleaning and a mild, non-abrasive cleaning agent for more stubborn residue. Rinse well.

- Clean solar panels more frequently during drier months, as they may become soiled more quickly.

**Note: During pressure washing, take care to avoid direct spray into drain holes on power module lid.**

- The main housing has several drain holes. Ensure that they are free of debris.
- Visual inspection – check over exterior assembly for cracks, missing or broken hardware or other potential problems annually.

**Batteries:** Be cautious when handling the battery pack. It is capable of generating hazardous short-circuit currents. Remove all jewelry (bracelets, metalstrap watches, rings) before attempting to handle or disassemble the battery pack.

**Consult your local municipal by-laws for information on recycling the cells. DO NOT THROW THE CELLS IN THE GARBAGE!**

## operation

Turn the rotary LIGHTING CONTROL switch to the lighting option desired. Factory set for Dusk to Dawn operation.

### Day-Night Transition

The SunLight uses the solar array to detect day and night. The transition to night requires a solar insolation level less than two percent. The transition back to day requires a high solar array open-circuit voltage. Both state changes require 10 minutes of continuous transition values before making the change. These constraints avoid false transitions due to lightning or dark storm clouds.

### Measure Night Length

The LIGHTING CONTROL options that turn the lights on again before sunrise require that the SunLight measure the length of the night. Therefore, the controller cannot turn the lights on before sunrise the first night after installation (or after reconnecting the battery). If the solar array is disconnected during service, the controller will then measure a faulty night length. Either reset the controller by reconnecting the battery, or this short "night" will be automatically corrected by the controller after four days of service.

### Low Voltage Disconnect (LVD)

If the battery falls below 11.7 volts, the load is disconnected from the battery to protect against harmful deep discharges. A one minute delay prevents load disconnects from transients. The load is automatically reconnected when the battery voltage recovers to 12.8 volts.

### Lighting Control options

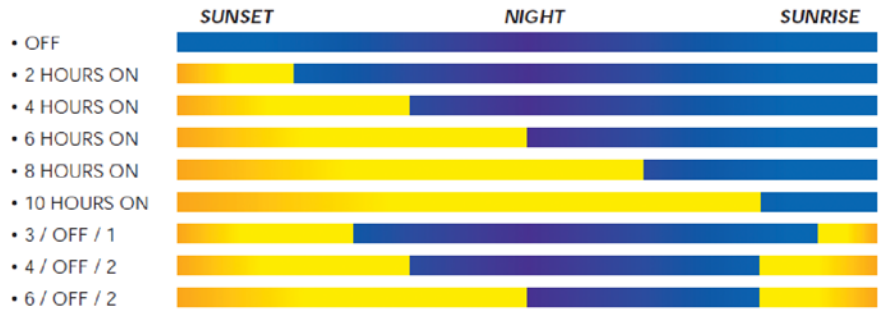

- OFF Lights remain turned off
- 2, 4, 6, 8, 120 Hours light is turned on after sundown
- 3/1, 4/2, 6/2, Light is turned on after sundown, turned off during the night, and turned on again one hour (3/1) or two hours (4/2, 6/2) before sunrise
- D/D Dusk-to-Dawn, light is on all night

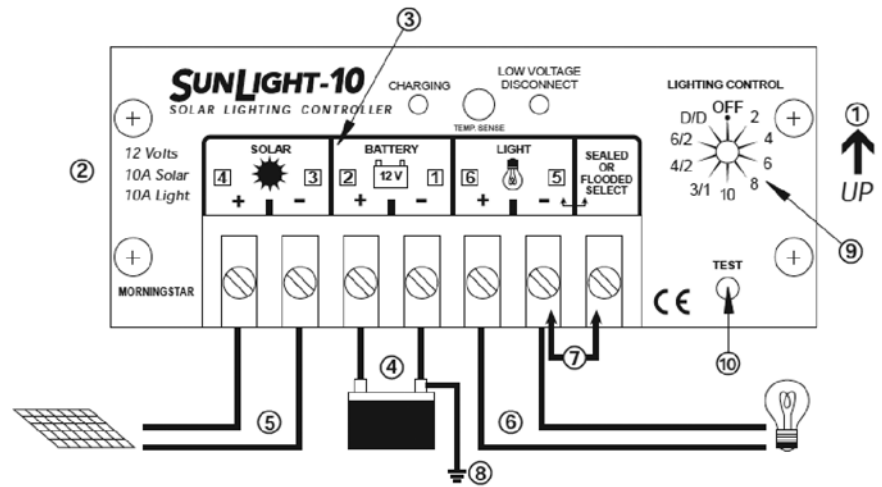

## troubleshooting

---

### **Load not operating properly**

1. Press the TEST button to turn the lights on. This will assist in troubleshooting the problem.
2. Check that the load is turned on. Check that no system fuses are defective. Check that no system circuit breakers are tripped. Remember that there are no fuses or circuit breakers inside the SunLight.
3. Check connections to the load, and other controller and battery connections. Make sure voltage drops in the system wires are not too high.
4. Check for proper LED indications on the SunLight. If the red LOAD DISCONNECT LED is on, the load has been disconnected due to low battery voltage. This is generally a normal state when the load exceeds the PV array output due to weather and other sunlight conditions.
5. Check the PV array voltage under direct sun, with the array leads disconnected. The voltage should be close to the expected open circuit voltage for the panel type used.
6. Visually inspect the PV array and verify that the array is clear of debris (e.g. leaves, snow, dirt) and that it is oriented correctly for the installation location.
7. Measure the voltage at the controller BATTERY terminals. If this voltage is above the LVD, the load should have power. Press the test button and then measure the voltage at the controller LOAD terminals, and if there is no voltage present, the controller may be defective.

# kaleidoscope® smart shelter installation/maintenance manual

## mechanical installation locations

**Note:**  
The 4-post unit uses one 2-post system and one 3-post system.

### 2-Post

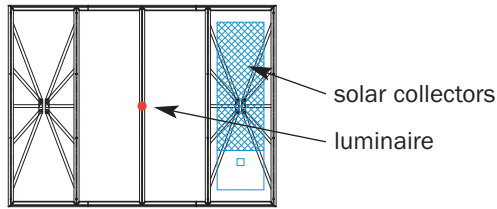

### 3-Post

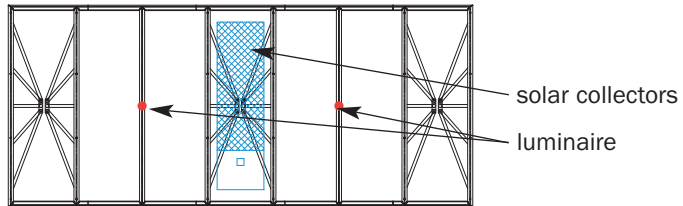

### 4-Post

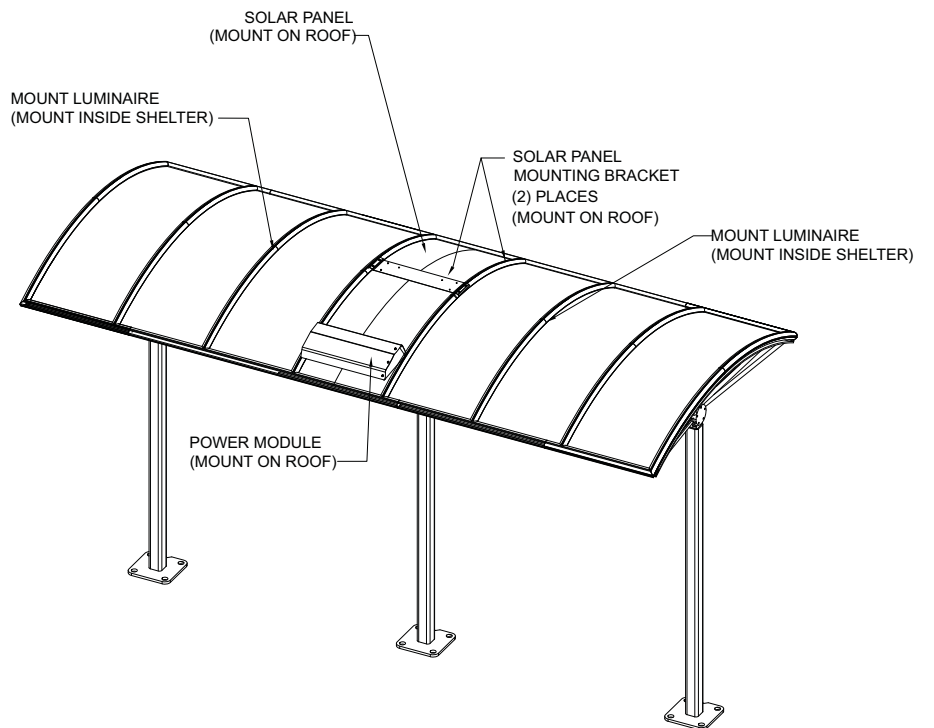
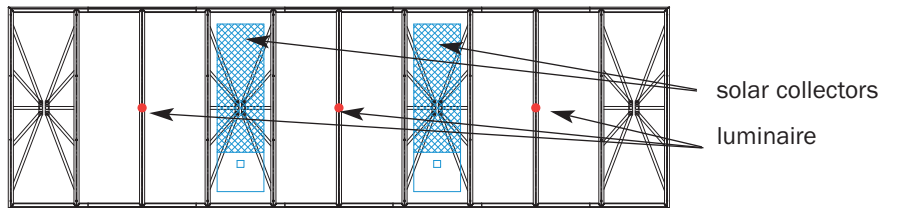

# kaleidoscope® smart shelter installation/maintenance manual

Kaleidoscope designed by Robert Chipman, ASLA;  
Brian Kane, IDSA; and Arno Yurk, AIA, IDSA.  
Kaleidoscope design is protected by Patent Numbers: D432,665; D420,812;  
D421,132; D429,000; D412,993; D413,314; D420,233; D420,812.

Specifications are subject to change without notice.

Kaleidoscope is manufactured in U.S.A.

©2011 Landscape Forms, Inc.

Printed in U.S.A.

## **OUR PURPOSE IS TO ENRICH OUTDOOR SPACES**

We believe in the power of design and its ability to influence and elevate the quality of public space. High quality products and outstanding customer experience make us one of the world's premier designers and manufacturers of outdoor commercial furnishings.

**landscapeforms®**

P 800.521.2546 F 269.381.3455  
431 Lawndale Avenue, Kalamazoo, MI 49048  
email [specify@landscapeforms.com](mailto:specify@landscapeforms.com)  
[www.landscapeforms.com](http://www.landscapeforms.com)