

Table options

### Included components:



Only tables with glass tabletops require some assembly. All metal and wood tables ship fully assembled.

- Tabletop hardware: (4) each for 42" square and 54" round tabletops. (8) each for 42" x 84" rectangular tabletops.
- (1) 5/32" hex key
- (1) Glass tabletop
- (1) Table base with glides factory installed

### Tools required:

Proper glass handling safety equipment, if necessary.

**ASSEMBLE WITH CARE!** Pangard II® Polyester Powdercoat is a strong, long-lasting finish. To protect this finish during assembly, place unwrapped powdercoated parts on packaging foam or other non-marring surface. Do not place or slide powdercoated parts on concrete or other hard or textured surface – this will damage the finish causing rust to occur. Use touch-up paint on any gouges in the finish caused by assembly tools.

Date: May 2, 2012

U.S. Patent Nos. D655,952; D655,951; D653,060; D652,656

### Installation:

Large 42" x 84" rectangular tabletop requires (6) each screws and washers. Small 42" square and 54" round tabletops require (4) each screws and washers.

1. Set table base in position.
2. Place rubber washer at each screw location.
3. Set tabletop in position on table base.
4. Install screws and washers in order shown in Fig. 1, using the included hex key.
5. Adjust glides to level table.

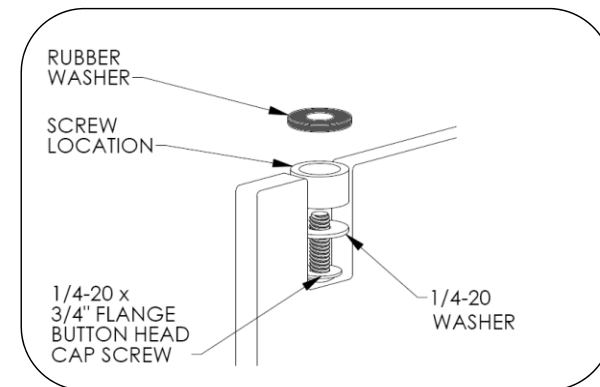

Fig. 1 – Tabletop attachment hardware