

Instructions

Assembly
Installation
Operation

7/2007

Robert Landscape Post with Alignment Strap

HANDLE WITH CARE! Robert has a sand blasted finish that can be scuffed by contact with tools, concrete, or other abrasive surfaces.

Recommended procedure for surface mounting:

Robert may be surface mounted to concrete footings 4" below finished grade with corrosion resistant anchor bolts provided by others. Although the installation procedure is the responsibility of the installer, we suggest the following:

1. Pour concrete footing with mounting surface 4" below finished grade. As a minimum, 12" diameter x 6" deep footings spaced 23 5/8" center to center will provide stability and adequate edge distance for 1/4" anchor bolts.
2. Position the first post on its footing. Mark hole locations. Remove the post. Drill holes for anchors. Fasten the first post to its footing.
3. Position the second post on its footing. Place an alignment strap on the posts with the convex side up. Mark hole locations for the second post and proceed as in step 2.
4. If the layout is not a loop, place one spacer (washer shaped part) on the end post (See Figure 1.). Screw a cap on the first post hand tight.
5. Repeat the process for each post.
6. When extra security is needed, use thread locking compound or a strap wrench with a polyurethane or rubber coated strap to tighten the caps.

Recommended procedure for embedding:

1. Prepare the excavation so that the square plates at the bottom of the posts will be 4" below finished grade.
2. Assemble posts and alignment straps as shown in figure 1. If the layout is not a loop, place one spacer on each end post before assembling the cap.
3. Pour the concrete.
4. When extra security is needed, use thread locking compound or a strap wrench with a polyurethane or rubber coated strap to tighten the caps.

Instructions

Assembly
Installation
Operation

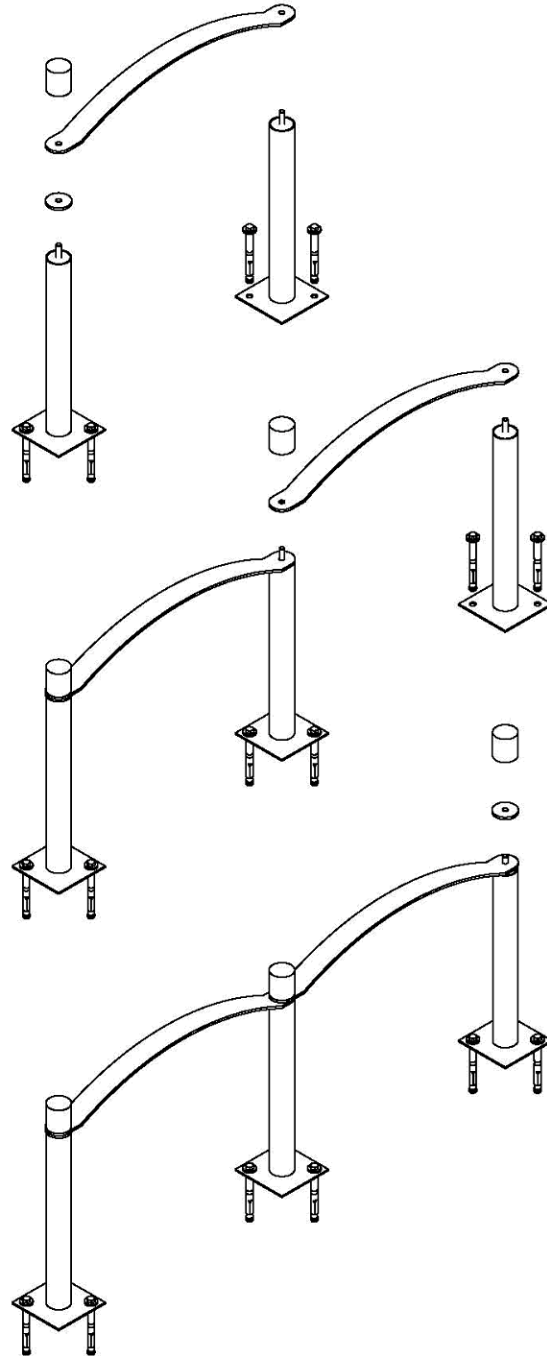

Figure 1

Example three post installation

landscapeforms®

431 Lawndale Avenue, Kalamazoo, MI 49048
PH: 800.521.2546, PH: 269.381.0396, FX: 269.381.3455