

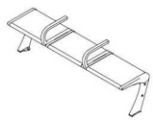

Series 512

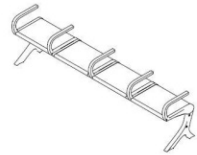

Series 513



Series 514



Series 515



Series 516

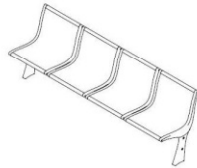

Series 517

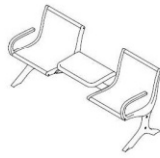

Series 518



Series 521

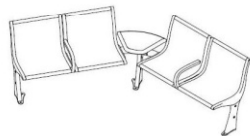

Series 525

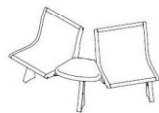

Series 531

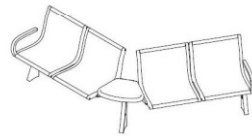

Series 535

Included components:

- Freestanding units are shipped with glides installed.
- Use only the anchoring hardware provided with the units.
- For Surface Mount units: Powers Fasteners Power-Bolt® #5934 stainless steel 1/2 x 4-3/4" hex head sleeve anchor (2) included for backless bench (4) included for backed straight bench (6) included for backed mitered bench
- For Embedded units: 1/2-13 x 5" anchor rods (4) included for straight bench (6) included for mitered bench

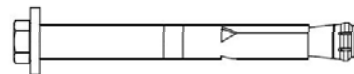

Surface Mount Anchor

Tools required:

For Surface Mount units:

- Hammer drill with 1/2" diameter carbide tipped drill bit
- Hammer
- 9/16" Wrench

For Embedded units:

- Hammer drill with 5/8" diameter carbide tipped drill bit
- Powers Fasteners AC100 PLUS™ or Hilti HIT RE 500 adhesive

ASSEMBLE WITH CARE! Pangard II® Polyester Powdercoat is a strong, long-lasting finish. To protect this finish during assembly, place unwrapped powdercoated parts on packaging foam or other non-marring surface. Do not place or slide powdercoated parts on concrete or other hard or textured surface – this will damage the finish causing rust to occur. Use touch-up paint on any gouges in the finish caused by assembly tools.

PROCEDURE FOR SURFACE MOUNT INSTALLATION:

Note: DO NOT DRAG bench across concrete or other rough surfaces. This could damage the powdercoat on the bottom of the surface mount plates.

1. Check screws that fasten anchor plates to support and tighten if necessary.
2. Place unit in desired position and mark anchor locations through holes provided in surface mount plates.
3. Move unit and drill holes.
4. Clear the holes of dust and debris using compressed air.
5. Place unit in desired position and install the sleeve anchors. Tighten as recommended by anchor manufacturer.
6. Periodically check fasteners and tighten if required.

PROCEDURE FOR EMBEDDED INSTALLATION:

1. Install threaded anchor rods into support castings to depth shown.
2. Place unit in desired position and mark locations of anchor rods on concrete.
3. Move unit and drill holes.
4. Clear the holes of dust and debris using compressed air.
5. Fill holes with adhesive to 1" below the top of each hole, filling from the bottom up to avoid air pockets.
6. Set unit in place. Wipe away excess adhesive before it gels.
7. Brace unit for support until adhesive has cured.

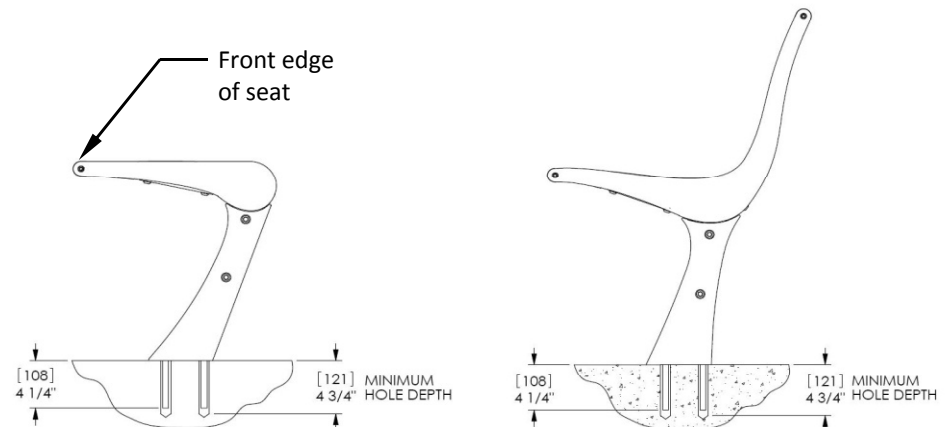

BACKLESS BENCH EMBEDMENT

BACKED BENCH EMBEDMENT

MINIMUM RECOMMENDED CONCRETE SLAB

5-1/2" [140mm] BASE THICKNESS, 3000 psi

DIMENSIONS GIVEN ARE MINIMUM UNLESS OTHERWISE NOTED

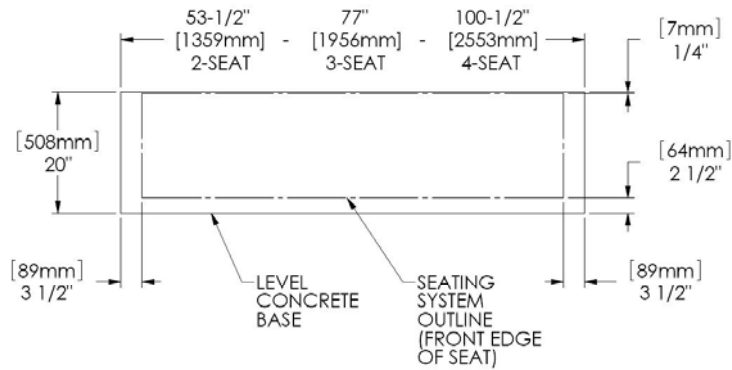

Figure 1: Backless Units

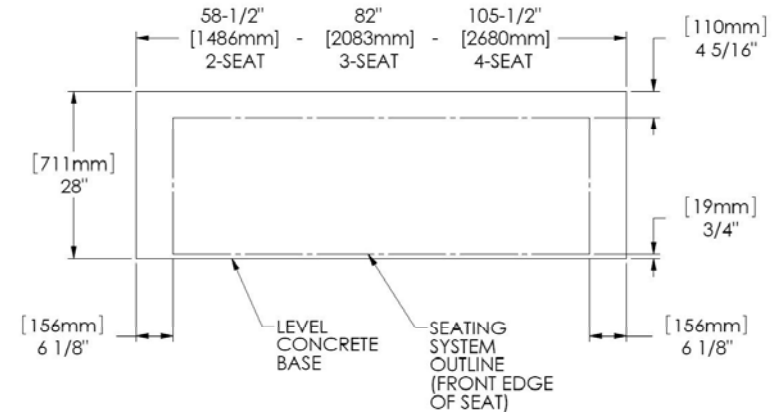

Figure 2: Backed Units

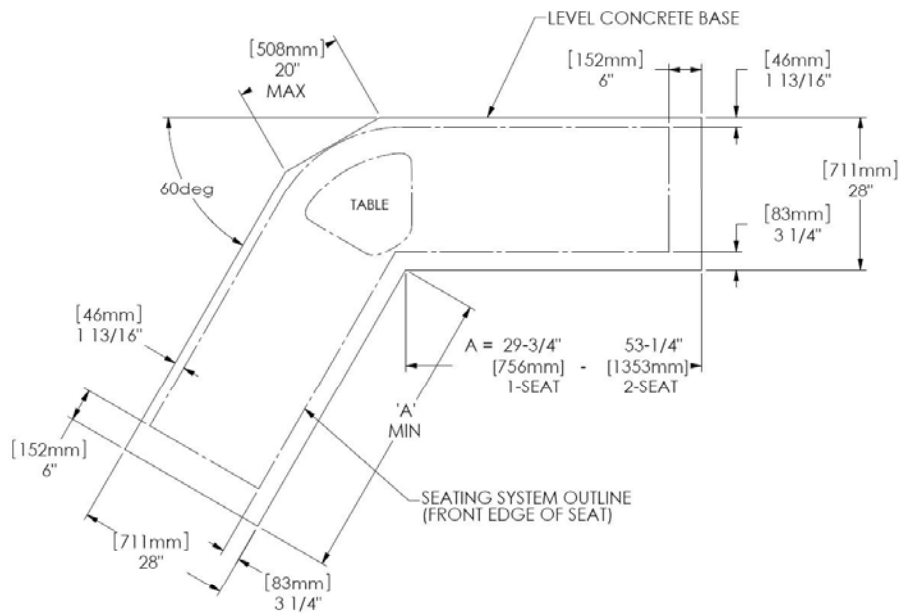

Figure 3: Inside Facing Units (Series 521 and 525 ONLY)

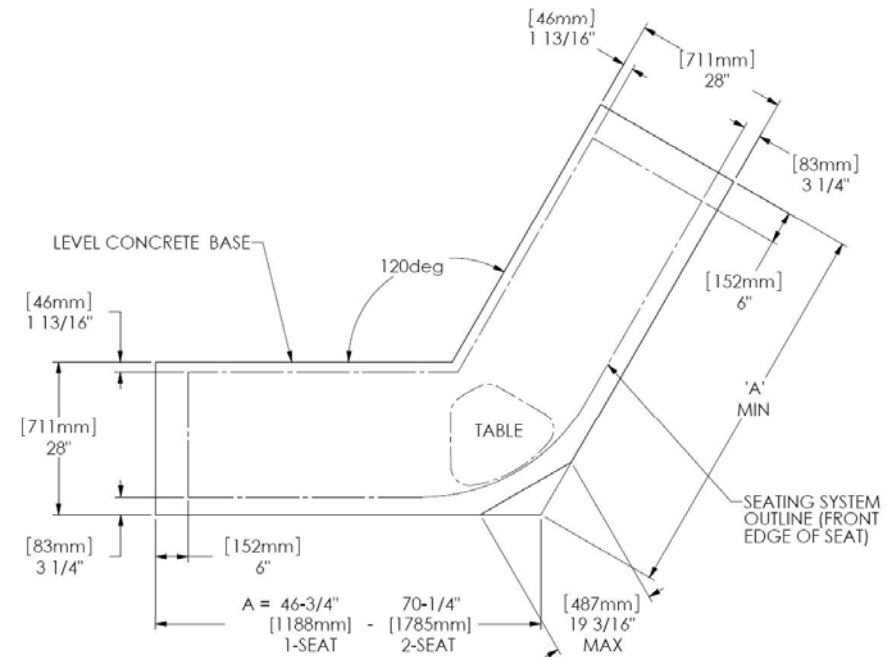

Figure 4: Outside Facing Units (Series 531 and 535 ONLY)