

Bench options

Included components:

- Bench ships fully assembled

Tools Required for Surface Mount option

- Safety glasses
- (4) Non-corrosive anchors, maximum 3/8-16 size, minimum 2-1/2" embedded length (anchors not included with bench)
- Blanket or other padded material, for protecting powdercoat finish

PROCEDURE FOR INSTALLATION:

1. Prepare proper concrete slab as required.
2. Freestanding bench ships with glides installed. Bench can be set in place.

Note: DO NOT DRAG bench across concrete or other rough surfaces. This could damage the powdercoat finish.

For SURFACE MOUNT bench:

1. Tip bench onto protective material and remove glides.
2. Set bench in place and mark hole locations.
3. Move bench and drill holes according to diameter and depth required by anchoring hardware manufacturer. Clear holes of debris.
4. Set bench over holes and install anchors.

ASSEMBLE WITH CARE! Pangard II® Polyester Powdercoat is a strong, long-lasting finish. To protect this finish during assembly, place unwrapped powdercoated parts on packaging foam or other non-marring surface. Do not place or slide powdercoated parts on concrete or other hard or textured surface – this will damage the finish causing rust to occur. Use touch-up paint on any gouges in the finish caused by assembly tools.

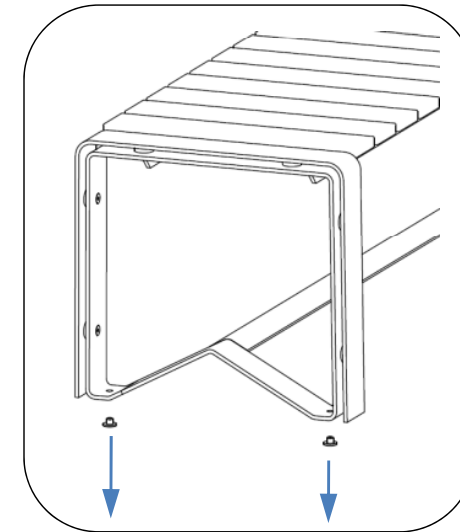

Fig. 1.1

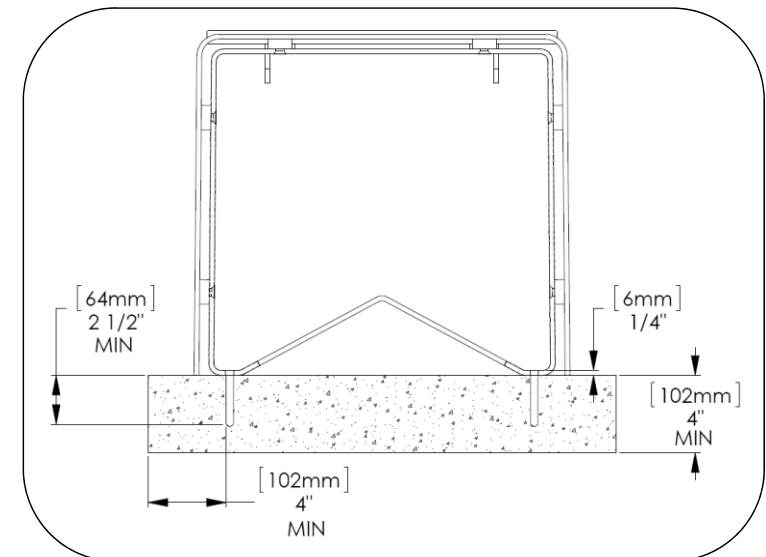

Fig. 1.2