

Surface Mount

Included hardware



1x – Lightpole assembly



4x – Cabinet cover



1x – LED driver



1x – Cabinet dome retainer bar



1x – Cabinet dome cover



4x – Cabinet cover screw

Tools Required

- Safety glasses
- Screwdrivers
- Wiring tools and connectors
- Anchoring hardware – (4)  $\varnothing 3/8$  (maximum) x 3-1/2" length stainless steel anchors. Landscape Forms recommends Power bolts or drop-in wedge anchors
- Hammer drill
- 3/16" hex key

**LIGHTING LAYOUT RECOMMENDATIONS:**

Although light pole spacing is the responsibility of others, the following can be used to help determine appropriate spacing:

Hawthorne distribution is an IES Type 4 pattern and meets or exceeds IESNA DG-5 for Park walkways, Class 1 bikeways, Residential sidewalks and Intermediate sidewalks at 25' pole spacing, and Commercial sidewalks at 15' pole spacing. Poles can also be spaced 15' apart on both sides of a 10' path for Public-Way Emergency Egress. Outside of North America, Hawthorne meets CIE-136-2000 for Residential Parks at 25' pole spacing.

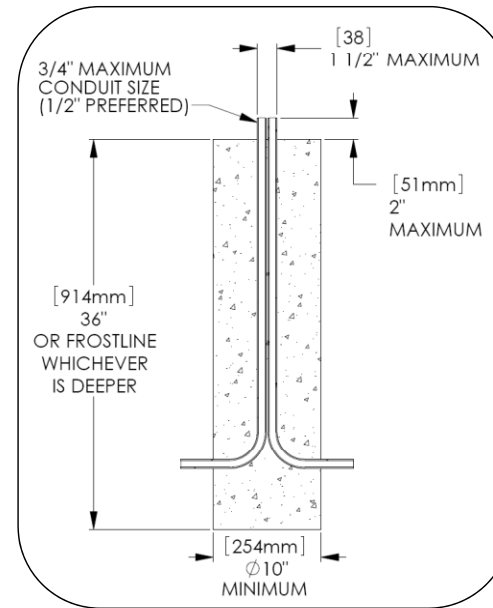

Fig. 1 – Minimum footing recommendation

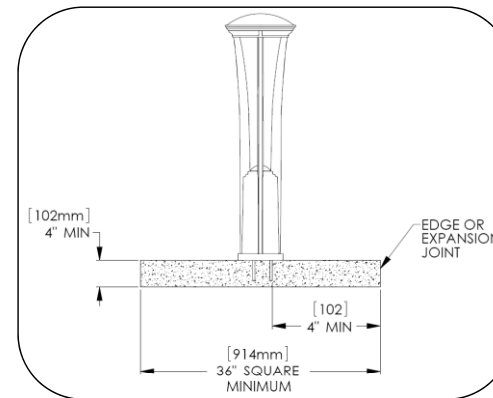

Fig. 2 – Minimum concrete slab size

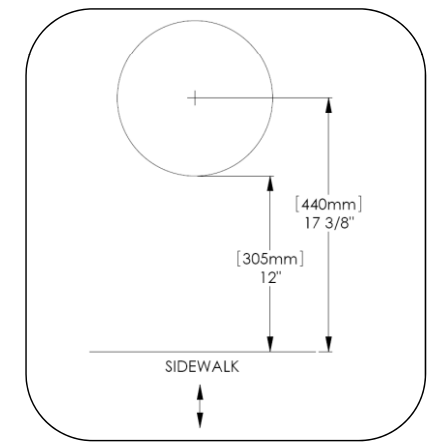

Fig. 3 – Recommended setback from sidewalk

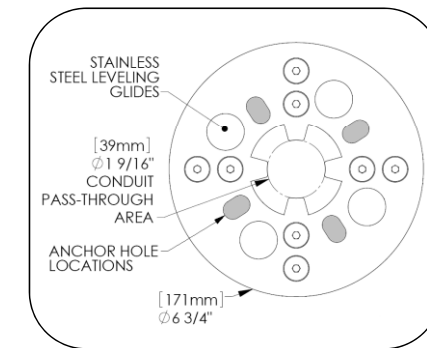

Fig. 4 – Bottom view

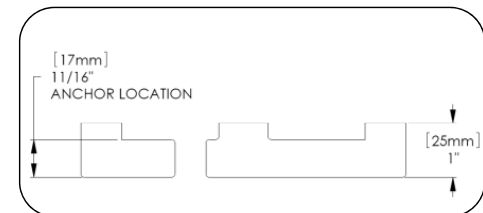

Fig. 5 – Base plate section view

**ASSEMBLE WITH CARE!** Pangard II® Polyester Powdercoat is a strong, long-lasting finish. To protect this finish during assembly, place unwrapped powdercoated parts on packaging foam or other non-marring surface. Do not place or slide powdercoated parts on concrete or other hard or textured surface – this will damage the finish causing rust to occur. Use touch-up paint on any gouges in the finish caused by assembly tools.

Landscape Forms is not responsible for site preparation and footings. Footing recommendations are included in these instructions.

### INSTALLATION PROCEDURE FOR LIGHT POLE:

1. Prepare footing as required by local codes, see Fig. 1, Fig. 2 and Fig. 3 for recommendations.
2. Set pathway light in position over conduit, ensuring that base sits flat on concrete.
3. Mark four anchor hole locations and move light unit.
4. Drill holes according to anchor size and depth. Clear holes of debris.
5. Set unit in place and install anchors according to anchor manufacturer's recommendations.
6. Using 3/16" hex key, adjust leveling glides until unit is plumb.

### PROCEDURE FOR INSTALLING CABINET COVERS:

1. Set retainer bar in the casting pocket.
2. Install cabinet covers as shown, ensuring bottom tab of cover rests in the groove in base casting. Repeat for remaining three covers.
3. Install cabinet dome cover by threading into the retainer bar until tight.

### PROCEDURE FOR WIRING HAWTHORNE:

The Hawthorne pathway light is assembled at the factory. The light cartridge is mounted into the head of the pole and will not need to be removed during installation. The LED cartridge is wired to the driver (located in the cabinet) at the factory.

The following schematic is to be used to connect the unit to line voltage. It is the responsibility of the installer to make sure that all connections are made in accordance with the NEC and local building codes. Connection hardware not included.

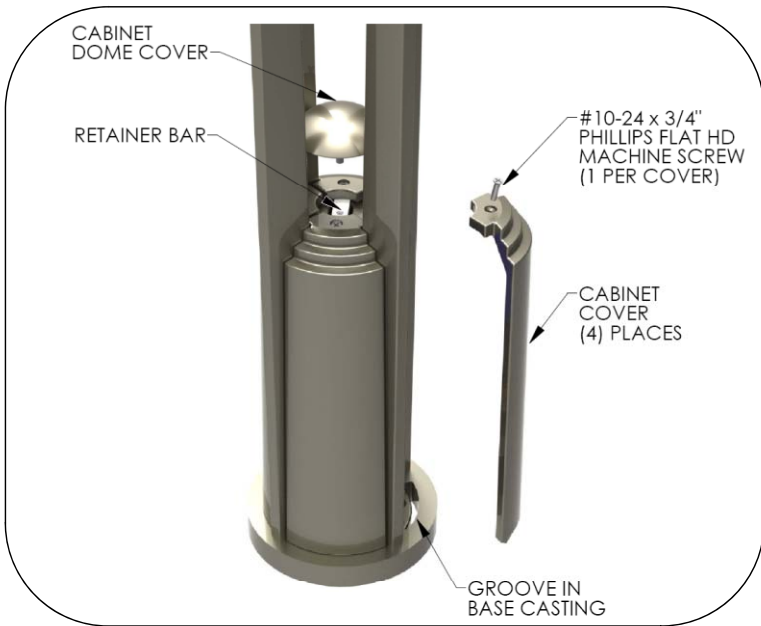

Fig. 6 – Remove access panel

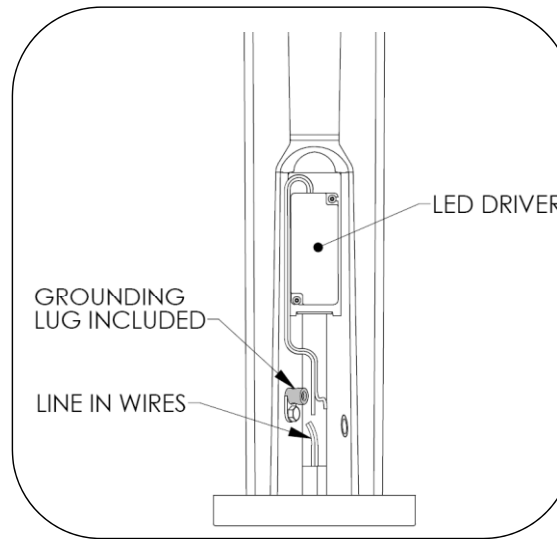

Fig. 7 – Access panel removed

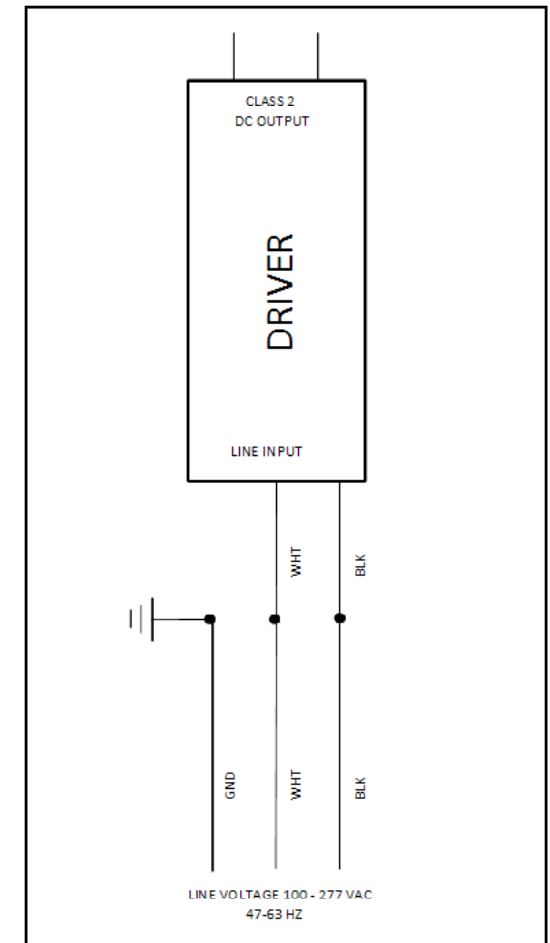

Fig. 8 – Hawthorne wiring schematic