

Bench options

Included components:

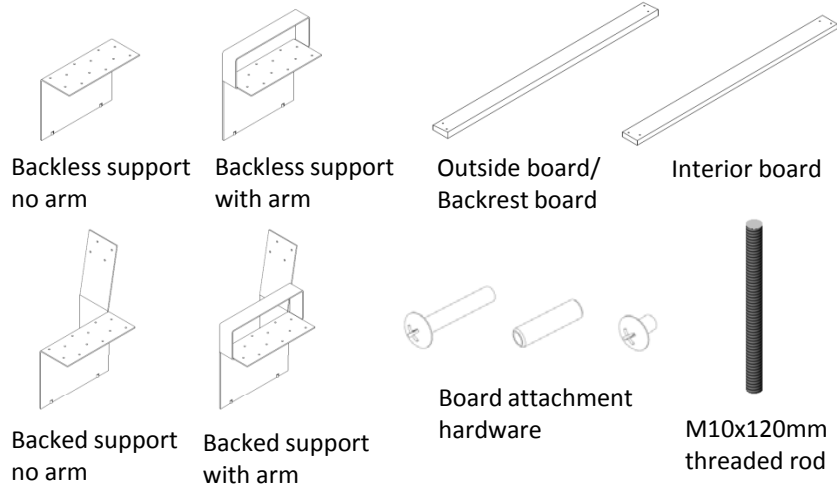

Tools required:

- Two #3 Phillips drivers
- For anchor holes: $\varnothing 7/16''$ drill
- Chemical anchoring adhesive, if specified
- Proper personnel for lifting bench

ASSEMBLE WITH CARE! Pangard II® Polyester Powdercoat is a strong, long-lasting finish. To protect this finish during assembly, place unwrapped powdercoated parts on packaging foam or other non-marring surface. Do not place or slide powdercoated parts on concrete or other hard or textured surface – this will damage the finish causing rust to occur. Use touch-up paint on any gouges in the finish caused by assembly tools.

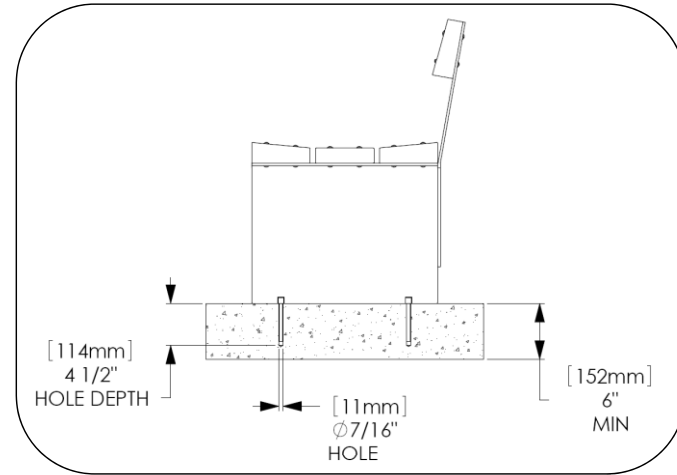

Fig. 1 – Drilled hole size, board orientation

INSTALLATION PROCEDURE:

Note: Interior seat boards are rectangular. Remaining boards are wedge-shaped. Seat boards and backrest boards may be different lengths. Refer to Fig. 8 for proper location of boards, depending on bench length.

1. Drill holes as shown in Fig. 2 as required per specified bench. Clear holes of debris.
2. Install threaded rods into supports.
3. Position first two supports so threaded rods drop into the drilled holes as shown in Fig. 4. Refer to Fig 8 for support placement for different bench styles.
4. Fasten seat boards and back board (if specified) as shown in Fig. 1, using board attachment hardware as shown in Fig. 3. Leave screws slightly loose until entire bench has been assembled.
5. Set next support in position and attach boards.
6. Tighten all screws and remove any burrs from screw heads.

For optional anchoring adhesive installation:

1. Follow steps 1 and 2 above.
2. Position first two supports as close to the drilled holes as possible without blocking access for dispensing adhesive. Refer to Fig 8 for support placement for different bench styles.
3. Follow steps 4 and 5 above.
4. Clean the drilled holes according to adhesive manufacturer's instructions.
5. Dispense adhesive into the holes, filling from the bottom to 2-1/2" from the top.
6. Using proper personnel, move the bench into position. Adhesive should rise to the top of the hole. Wipe away excess adhesive from supports.
7. Tighten all screws and remove any burrs from screw heads.

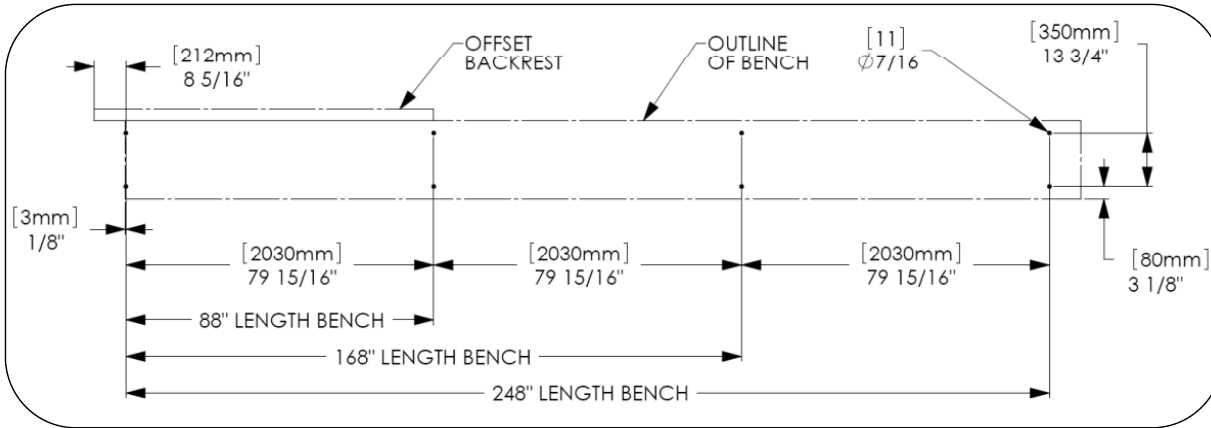

Fig. 2 – Anchor locations

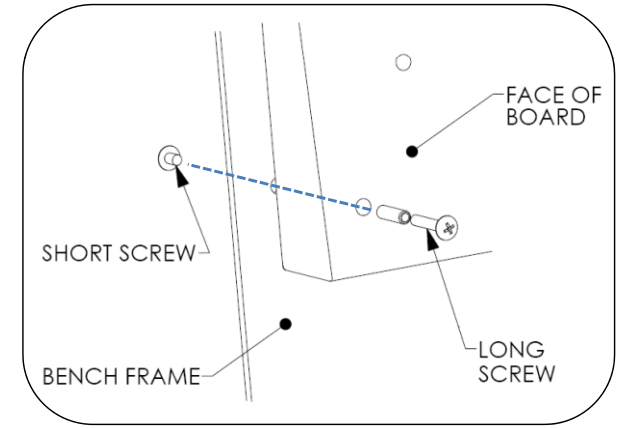

Fig. 3 – Board attachment hardware

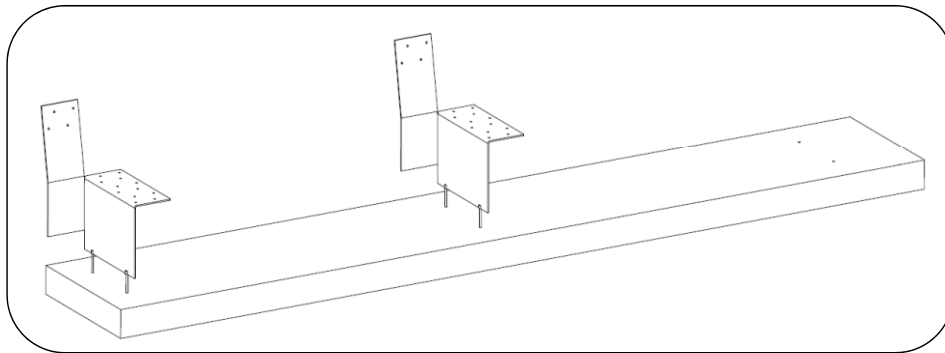

Fig. 4 – Step 1

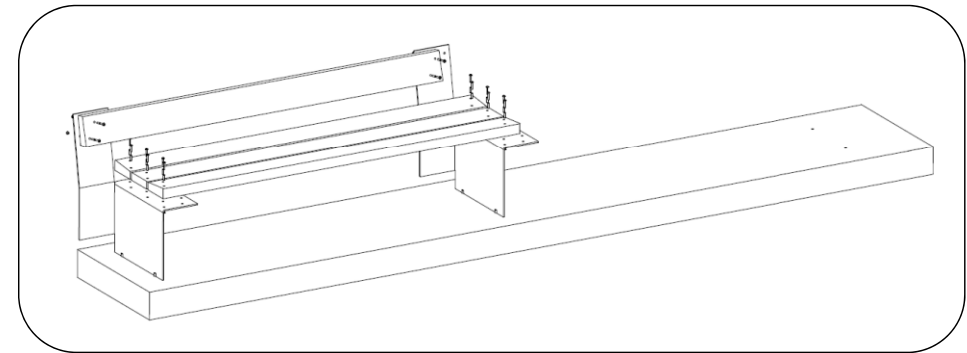

Fig. 5 – Step 2

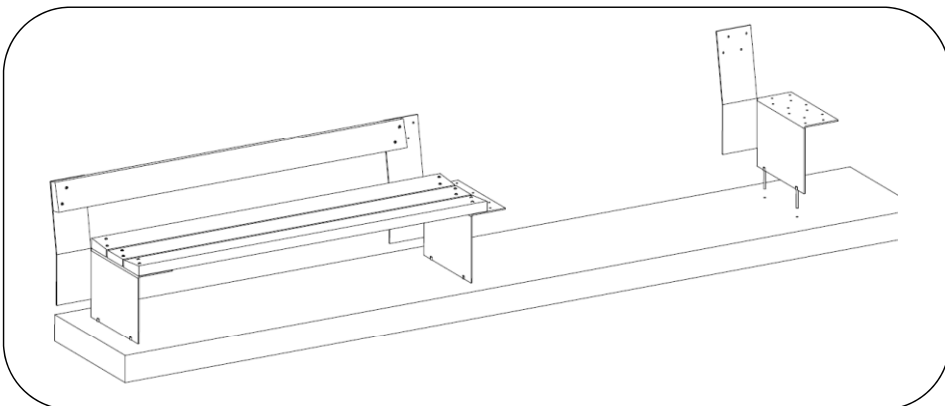

Fig. 6 – Step 3

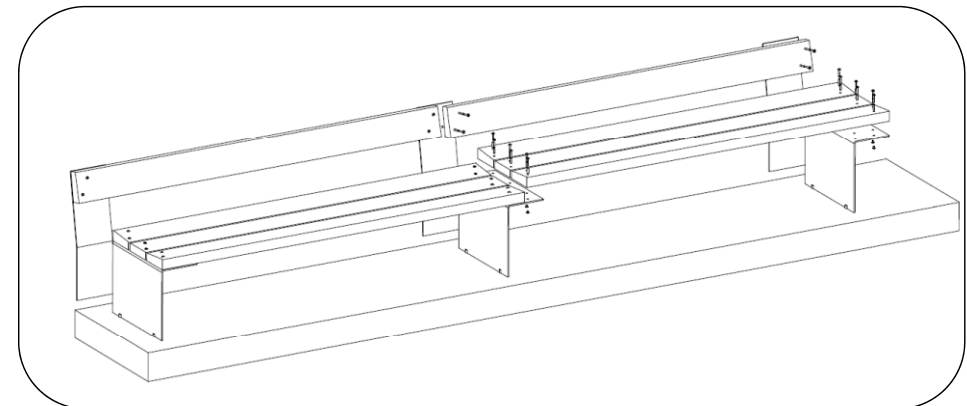

Fig. 7 – Step 4

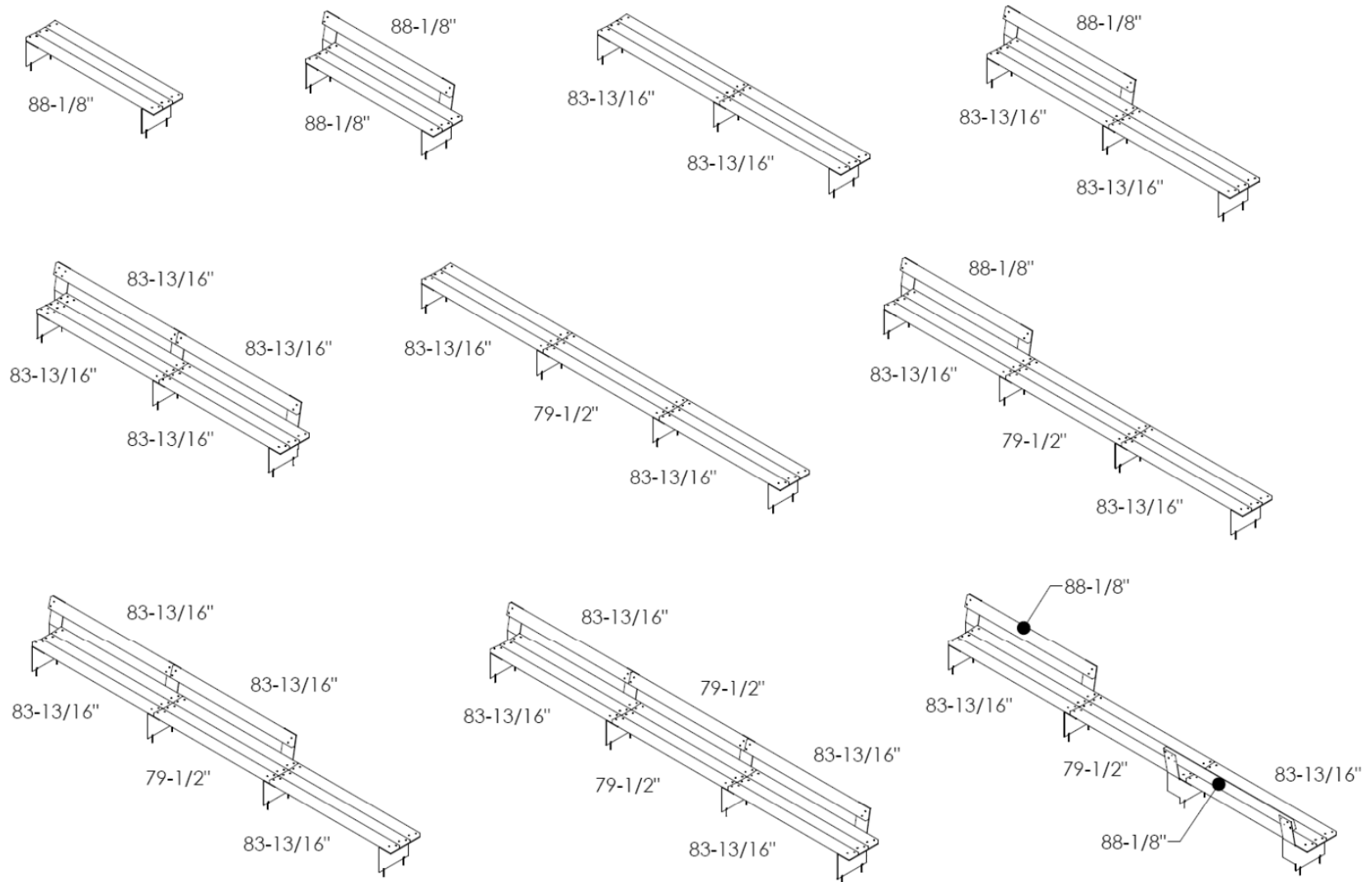

Fig. 8 – Board length locations and support orientations